

UK STEEL

Powered by  uk

UK Steel Code of Practice:

Design, Installation & Maintenance of Oxygen Pipework Systems

INTRODUCTION	4
PROPERTIES OF OXYGEN.....	4
Ownership	4
Implementation & Compliance	5
UK Steel's Liability	5
Legal Disclaimer	5
1 SCOPE	6
2. REFERENCES	6
3. HEALTH AND SAFETY REGULATIONS:	7
4. DEFINITIONS	8
5. SAFETY	8
5.1 Competent Person.....	8
5.2 Safety Considerations	8
5.2.1 Fire Safety Management.....	8
5.3 Causes and Avoidance of Oxygen Enrichment	9
5.4 Confined Spaces	9
5.5 Fire Hazards from Oxygen Enrichment	9
5.6 Combustibility of Materials.....	9
5.7 Hotwork	10
5.8 Smoking.....	10
5.9 Earthing	10
5.10 Oxygen Cleanliness.....	10
5.11 Leakage.....	10
6. DESIGN – MATERIAL CONSIDERATIONS	10
6.1 General.....	10
6.2 General Design and Metallic Material Selection	10
6.3 Non Metallic Materials	13
7 - DESIGN.....	13
7.1 Isolation Facilities	13
7.2 Throttling or Process Control Valves	14
7.3 Filters.....	14
7.4 Flow Measuring Devices.....	14
7.5 Protection Systems.....	14
7.6 Pressure Relief	15
7.7 Vent Lines.....	15
7.8 Line Valves for Portable Equipment	15
7.9 Dust Traps & Dead Pipework	16

Reference	Page	Issue No.	Revision No.	Date
UKS Oxygen COP	1	1	2	16/04/19

7.10 Electrical Continuity	16
7.11 Insulating Joints	16
7.12 Expansion Loops	16
7.13 Flexible Connections	16
7.14 Noise Reduction Devices.....	16
7.15 Other Accessories	16
7.16 Lubricants	16
7.17 Location of Pipework Away from Hazards	16
7.18 Risk of Ignition from Arcing in Electrical Apparatus	17
7.19 Pipework Supports	17
7.20 Identification of Pipework.....	17
7.21 Compounds	17
7.22 Gas Control & Metering Stations	17
7.23 Painting.....	17
8. ADDITIONAL DESIGN REQUIREMENTS FOR UNDERGROUND PIPEWORK.....	17
8.1 Pipework in Ducts.....	17
8.2 Pipework in Filled Trenches.....	17
8.3 Pipework Under Roads and Railways	18
8.4 Pipework Adjacent to Existing Services.....	18
8.5 Underground Valves.....	18
8.6 Identification of Underground Pipework.....	18
8.6.1 Pipework in Filled Trenches.....	18
8.6.2 Surface Markers	18
8.7 Corrosion Protection.....	18
8.8 Specialized surveys.....	18
9. CLEANING & FABRICATION	19
9.1 Cleaning Prior to Fabrication	19
9.1.1 Cleaning Steel Pipes and Fittings (excluding stainless steel)	19
9.1.2 Cleaning Copper Pipe and Fittings.....	19
9.1.3 Cleaning Valves and Other Components	19
9.1.4 Clean Work Area	19
9.1.5 Inspection & Protection	20
9.2 Fabrication.....	21
9.2.1 General.....	21
9.2.2 Bends in Steel Pipe	21
9.2.3 Copper Pipes and Fittings.....	21
9.2.4 Non-Destructive Examination.....	21

Reference	Page	Issue No.	Revision No.	Date
UKS Oxygen COP	2	1	2	16/04/19

9.2.5 Gaskets	21
9.2.6 Pressure Testing of Fabricated Pipework.....	21
9.2.7 Quality Inspection	22
9.3. Cleaning Pipe Fabrications & Pipework Systems Before & After Final Installation.	22
9.3.1 Cleaning by Pigging	22
9.3.2 Where Pigging is Impracticable.....	22
9.3.3 Removal of Degreasing Agents	22
9.3.4 Blowing out of Pipework.....	23
9.3.5 Cleanliness Inspection (Supplied Equipment)	23
9.3.6. Cleanliness Inspection	23
9.3.7 Detection Limits	23
9.3.8 Acceptance Criteria	23
10. ASSEMBLY & INSTALLATION	26
10.1 Supports, Guides & Anchors	26
10.2 Pressure testing of the complete installed pipework/pipe system.....	26
10.2.1 General.....	26
10.2.2 Initial Leak Test.....	26
10.2.3 Proof Strength Test.....	26
10.2.4 Acceptance Test.....	26
10.2.5 Delayed Commissioning	27
11. COMMISSIONING/DE-COMMISSIONING	27
11.1 Pre-Commissioning Checks	27
11.2 Personnel	27
11.3 Oxygen Pressurisation (and Venting)	27
12. OPERATION OF PIPEWORK SYSTEMS.....	28
13. MAINTENANCE OPERATIONS.....	28
13.1 General.....	28
13.2 Preventative Non-Intrusive Maintenance.....	28
13.3 Intrusive Maintenance	28
14. INFORMATION TO 3 rd PARTIES, WORKS ADJACENT TO PIPEWORK & DOCUMENT UPDATES	29
15. LIFECYCLE DOCUMENTATION	29
APPENDIX A.....	30
APPENDIX B.....	31
APPENDIX C.....	32
APPENDIX D.....	33
APPENDIX E	34
APPENDIX F	35

Reference	Page	Issue No.	Revision No.	Date
UKS Oxygen COP	3	1	2	16/04/19

DESIGN, INSTALLATION AND MAINTENANCE OF OXYGEN PIPEWORK SYSTEMS

INTRODUCTION

This UK Steel Code of Practice (CoP) was prepared as a result of reviewing the Corus Engineering Standard EIS1 (2002) and other relevant documents. Please see references (page 6).

It is essential to ensure that all engineering operations on oxygen systems are carried out to a high standard and that all personnel involved observe the appropriate safety procedures and are deemed competent to fulfil all aspects of their role.

Oxygen is classified as a dangerous substance and must be treated with the appropriate respect at all times. Whatever the incentive procedures should never be short cut and if in doubt, a competent person should be consulted.

Employers are legally required to assess the risks in the workplace and take all reasonable practical precautions to ensure the safety of workers, and include a careful examination of the risks from using and working on oxygen systems in the Risk Assessment/Method Statement documentation.

At all times a safe system of work must be applied and adhered to in accordance with the Health & Safety at Work Act 1975 section 2(a)

The information detailed within this CoP covers the dangers and precautions to be taken to ensure that every user working on oxygen systems can do so with confidence and without danger

Anyone undertaking work on oxygen systems must be familiar with the properties and hazards associated with oxygen.

This Code of Practice incorporates best practices and sets out the minimum requirements for the design, installation, modification and maintenance of gaseous oxygen systems to ensure safety both in any engineering activity and subsequent operation of the system

In this Code of Practice the word 'shall' is used to indicate a mandatory requirement while the word 'should' is used to indicate a recommended practice. Pressures are expressed in bar and should be assumed, unless otherwise stated to be gauge pressure.

This Code of Practice shall not be held as limiting any right of companies using it or any obligation of contractors under any contractual arrangement.

PROPERTIES OF OXYGEN

Gaseous oxygen is colourless, odourless and tasteless, non-toxic and heavier than air. It is non-flammable but supports combustion vigorously when the ignition temperature has been reached. Materials that will burn normally in air do so much more vigorously and at higher temperatures in oxygen. At increased pressures the ignition temperatures of all materials are reduced. In addition, materials that normally do not burn in air, e.g. steel, will burn in oxygen.

Do not use any hydrocarbons, such as oil and grease, in any system where there will be contact with oxygen. High oxygen velocities can result in ignition if entrained particles impact on other internal surfaces. Cleanliness in the preparation, fabrication and installation of any oxygen system is of the utmost importance to avoid any circumstances that may cause ignition and subsequent combustion.

Generally there are three factors that combine to produce a fire or explosion in an oxygen pipework and therefore should not be allowed to coincide. They are:

- a) Ignition
- b) Material for combustion
- c) Oxygen to support combustion

Ownership

The information contained in this document is based on joint work by UK Steel (representing steel producers and steel converters in the UK), BCGA and BOC. This Code of Practice is owned, and published by UK Steel. As owners, UK Steel are accountable for the ongoing review and are the only persons authorised to amend this document.

Reference	Page	Issue No.	Revision No.	Date
UKS Oxygen COP	4	1	2	16/04/19

This Code of Practice has been submitted to the Health and Safety Executive (HSE) for consultation and received their endorsement as industry best practice.

Implementation & Compliance

This document is aimed at delivering practical advice and assistance on design, manufacture, installation, commission and maintenance of gaseous oxygen pipework systems, including modifications or intrusive maintenance to existing systems. Adherence to guidance is not legally binding.

UK Steel's Liability

Notwithstanding any provision of this Code, UK Steel shall have no liability in respect of this Code whether in contract, tort (including but not limited to negligence), breach of any statutory duty, under statute, restitution, misrepresentation or otherwise (in each case whether caused by negligence or otherwise) arising out of or in connection with this Code or its performance.

UK Steel shall have no liability for any loss of profit, loss of sales, loss of business, loss of goodwill or reputation, third party claims or pure economic loss (in each case whether direct or indirect) or for any indirect or consequential loss in connection with this Policy.

UK Steel shall have no liability for any such matter that arises from the act or omission in connection with this policy by anybody, corporation, undertaking, association or individual user, their employees, agents, customers, sub-contractors or suppliers.

Legal Disclaimer

The material published in the Code is for general information purposes only and does not and is not intended to constitute legal or other professional advice. In particular, you should note that the content of this code may not be appropriate for all circumstances and will need to be tailored to fit different circumstances. You should seek specific legal and professional advice in relation to any particular matter.

Where we have included references to other sources, these are current only at the time of publication and UK Steel does not necessarily endorse the contents of those third party sources. UK Steel disclaims all liability arising from the information or materials contained in any such sources.

Reference	Page	Issue No.	Revision No.	Date
UKS Oxygen COP	5	1	2	16/04/19

1 SCOPE

This CoP applies to all new systems, modifications or intrusive maintenance to existing systems. It is not intended to apply retrospectively to existing systems. This CoP deals with design, fabrication of new and modification to existing systems, commissioning, operation, inspection and maintenance, decommissioning and demolition of gaseous oxygen pipework distribution systems and control stations up to and including the service outlet valve.

This CoP covers metallic oxygen transmission and distribution piping systems, as shown in diagram 1. It is limited to gaseous oxygen in a temperature range between minus 30°C to plus 200°C, pressures up to 40barg and a dew point of minus 30°C.

This CoP applies only to gases that contain more than 90% oxygen by volume, but no more than 99.9%.

The Code of Practice does not cover:

- (a) Liquid oxygen storage vessels.
- (b) Compressed gas cylinders, and associated equipment, including lances and flexible hoses connected to a fixed system.
- (c) Ultra-pure oxygen systems (greater than 99.9% oxygen by volume)

2. REFERENCES

The following are referred to and or taken into consideration in this Code of Practice:

BS 1306	Specification for copper and copper alloy pressure piping systems
BS 1710	Specification for identification of Pipework and services
BS 1723	Specification for brazing
BS EN 837-1	Pressure gauges. Bourdon tube pressure gauges. Dimensions, metrology, requirements and testing
BS 2633	Specification for Class I arc welding of ferritic steel pipework for carrying fluids
BS EN 1057	Copper and copper alloys. Seamless, round copper tubes for water and gas in sanitary and heating applications
BS EN ISO 17636-2	Non-destructive testing of welds. Radiographic testing. X- and gamma-ray techniques with digital detectors
BS EN ISO 17636-1	Non-destructive testing of welds. Radiographic testing. X- and gamma-ray techniques with film
BS 4515-1	Specification for welding of steel pipelines on land and offshore. Carbon and carbon manganese steel pipelines
BS EN 10217-1	Welded steel tubes for pressure purposes. Technical delivery conditions. Non-alloy steel tubes with specified room temperature properties
BS EN 10216-1	Seamless steel tubes for pressure purposes. Technical delivery conditions. Non-alloy steel tubes with specified room temperature properties
BS EN 10217-3	Welded steel tubes for pressure purposes. Technical delivery conditions. Alloy fine grain steel tubes
BS EN 10217-5	Welded steel tubes for pressure purposes. Technical delivery conditions. Submerged arc welded non-alloy and alloy steel tubes with specified elevated temperature properties
BS 4800F	BS 4800 Colour matching fan

Reference	Page	Issue No.	Revision No.	Date
UKS Oxygen COP	6	1	2	16/04/19

ISO 8501-1	Preparation of steel substrates before application of paints and related products -- Visual assessment of surface cleanliness -- Part 1: Rust grades and preparation grades of uncoated steel substrates and of steel substrates after overall removal of previous coatings
BS EN ISO 3183	Petroleum and natural gas industries. Steel pipe for pipework transportation systems
BS EN 14324	Brazing. Guidance on the application of brazed joints
BS EN 13636	Cathodic protection of buried metallic tanks and related piping
BS EN 15112	External cathodic protection of well casing
BS EN 60079-0:2012+A11:2013	Explosive atmospheres. Equipment. General requirements
ASME B31.3	Process Piping
CP 2010-2	Code of practice for Pipework. Design and construction of steel Pipework in land
EIGA-IGC Doc 13/12/E	The European Industrial Gasses Association (EIGA) Oxygen Pipework and Piping Systems
EIGA-IGC Doc 33/06/E	The European Industrial Gasses Association (EIGA) Cleaning of Equipment for Oxygen Service
API 1104	Welding of Pipework and Related Facilities
BOC	Oxygen Gas Risks

3. HEALTH AND SAFETY REGULATIONS:

The Control of Major Accident Hazards Regulations

The Health and Safety at Work ETC. Act

The Management of Health and Safety at Work Regulations

The Carriage of Dangerous Goods and Use of Transportable Pressure Equipment Regulations

Pressure Systems Safety Regulations

The Dangerous Substances and Explosive Atmospheres Regulations (DSEAR)

The Equipment and Protective Systems Intended for Use in Potentially Explosive Atmospheres Regulations 1996 (EPS)

GS4 Safety requirements for pressure testing

Confined Spaces Regulations

GS5 Confined spaces

Control of Substances Hazardous to Health (COSHH)

Pipework Safety Regulations

The Construction (Design and Management) Regulations

HSE Oxygen use in the workplace

HSE Design Codes - Pipe work

BCGA GN11

BGCA GN34

Reference	Page	Issue No.	Revision No.	Date
UKS Oxygen COP	7	1	2	16/04/19

Health and Safety (First-Aid) Regulations

HSE Publications: Free Leaflets - First Aid

Reporting of Injuries, Diseases and Dangerous Occurrences Regulations

Unless stated otherwise, the latest edition of any standard or document and amendment thereto, current at the date of any order or contract shall apply.

4. DEFINITIONS

Competent Person

A competent person is someone who has sufficient training and experience or knowledge and other qualities that allow them to assist you properly. The level of competence required will depend on the complexity of the situation and the particular help you need.

Pipework: a pipe or system of pipes together with associated valves, pumps, compressors and other pressure containing components and includes a hose or bellows but does not include a pipeline

Station: an above ground train of pipework controls and devices designed to control and meter the gas flow through the pipework system.

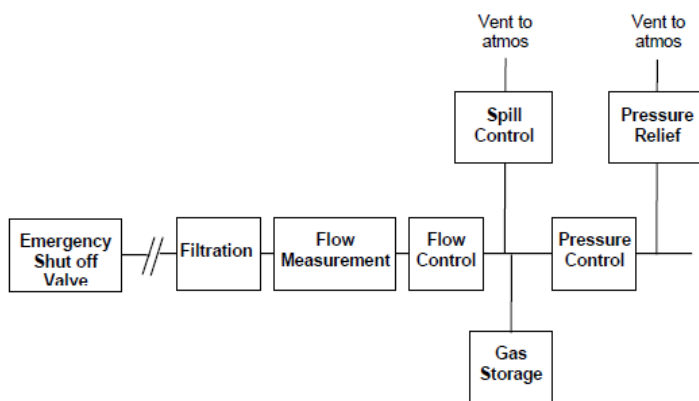

Diagram 1: Typical components of an oxygen process control system.

5. SAFETY

5.1 Competent Person

When installation or maintenance work on any gaseous oxygen system is to be carried out a competent person shall be appointed to take complete control and establish all necessary communication routes.

5.2 Safety Considerations

All installation and maintenance work on any gaseous oxygen system irrespective of its ownership shall be carried out in accordance with local safety requirements, safe working procedures and relevant statutory requirements. Preparation of a risk assessment relevant to the work is mandatory.

Information shall be available to all personnel on the actions to be taken by personnel, first aiders and fire-fighting teams in the event of an incident.

Operating personnel must at all times obey works rules and regulations and, where called for, Personal Protective Equipment (PPE) must be worn.

5.2.1 Fire Safety Management

Under oxygen-rich conditions the optimum fire-fighting materials are water or extinguishers containing dry chemical powder or carbon dioxide.

In the event of a major escape, switch off all electrical appliances in the area concerned and extinguish all naked flames.

The DSEAR and EPS assessments (see page 7) should be done as part of the overall fire safety management regime. Outputs from the DSEAR assessment will be relevant to various

Reference	Page	Issue No.	Revision No.	Date
UKS Oxygen COP	8	1	2	16/04/19

considerations required to be made under the Regulatory Reform (Fire Safety) Order 2005. DSEAR compliance and general fire safety therefore are closely linked.

A person whose clothing catches fire should be thoroughly soaked with water from a hose or series of buckets and removed into fresh air as soon as possible

It is very dangerous to attempt a rescue of a person on fire in an oxygen enriched atmosphere as the rescuer will most probably catch fire themselves. In certain cases, it may be possible to enter such a space if the rescuer is totally deluged with water and protected by constant water hosing

5.3 Causes and Avoidance of Oxygen Enrichment

Oxygen enrichment of the atmosphere is best guarded against by careful attention to the following points:-

- Where practicable ensure all areas that may be subject to oxygen enrichment are well ventilated
- Sources of ignition, i.e. electrical equipment, hot work, etc. should be closely control and isolated from areas where oxygen enrichment could occur
- Newly installed equipment for oxygen service should be thoroughly leak tested by a competent person and a timed gas pressure drop test carried out. This must be supplemented by testing with an approved leak test fluid which is compatible with the equipment for which it is being used. Alternatively, a solution of 1% "Teepol" in demineralised water may be used
- All equipment, for instance welding/cutting nozzles and hose connections, must be properly fitted. Hoses and other equipment should be kept leak tight and protected from damage
- All maintenance and repair work shall be carried out by an experienced and fully competent person
- When the work period is over, the cylinder valve or oxygen supply stop valve must be turned off. This is to avoid possible oxygen leakage between the work periods
- The gas valves on blow pipes/lances or cutting torches should not be relied upon for isolation of the oxygen supply
- Gas cylinders in use should be secured in an upright position
- A means of positive isolation should be in place during any maintenance procedure

5.4 Confined Spaces

Work undertaken in confined spaces must be carried out in accordance with Confined Spaces Regulations. This must recognise the potential hazards of both oxygen enrichment and deficiency. A specific confined space risk assessment is required with control measures identified and put in place I accordance with BCGA GN11.

Monitoring equipment, if used, should be capable of detecting enrichment, as well as depletion which could lead to asphyxiation.

5.5 Fire Hazards from Oxygen Enrichment

Oxygen reacts with most elements. The initiation, speed, vigour and extent of these reactions depend in particular upon: -

- Concentration, temperature, pressure of the reactants
- Ignition energy
- Mode of ignition

5.6 Combustibility of Materials

Nearly all materials will become more combustible in an enriched oxygen atmosphere – even materials that are usually not flammable.

Note: -

Anyone exposed to oxygen should not smoke or go near naked flames until they have been properly ventilated. Clothing exposed to high oxygen levels can remain saturated for some time and therefore be at risk of combustion. A period of 5 minutes in fresh air with movement of the arms and legs and coat unbuttoned should be the minimum safety measure.

Reference	Page	Issue No.	Revision No.	Date
UKS Oxygen COP	9	1	2	16/04/19

5.7 Hotwork

Safe systems of work documentation prior to commencement of work shall be in place for all hotwork activity. No welding, cutting or any hotwork shall be carried out on any steel pipe, vessel or component containing oxygen. See also Section 13.3. Similar work shall only be executed on copper pipe work when the oxygen pressure has been reduced to that of the atmosphere.

5.8 Smoking

Smoking shall be forbidden in any areas where there is the potential for oxygen enrichment.

5.9 Earthing

Oxygen pipe work systems shall not be used to provide an earth return for welding equipment.

5.10 Oxygen Cleanliness

Oil and grease are particularly hazardous in the presence of oxygen as they can ignite spontaneously and burn with explosive violence. Oils and Greases should never be used to lubricate oxygen or enriched air equipment. Special lubricants which are compatible with oxygen must be used.

When cleaning for oxygen service only approved degreasing agents shall be used, and the appropriate precautions taken in accordance with COSHH regulations.

5.11 Leakage

Any leakage should be immediately reported, the immediate area evacuated, and control measures put in place to prevent escalation of the hazard.

6. DESIGN – MATERIAL CONSIDERATIONS

6.1 General

Design of new installations and modifications to existing installations shall be in accordance with Pressure Equipment (Safety) Regulations and current standards.

Oxygen pipe work should wherever possible, be installed above ground. Additional design requirements for underground pipework are given in Section 8.

Consideration shall be given to protection from external impact and the surrounding environment.

6.2 General Design and Metallic Material Selection

Pipe design (including material selection) is a specialist activity requiring specialist knowledge and skills. Pipe construction (and many aspects of modification and extension) is construction work as defined in the Construction (Design and Management) Regulations 2015. The pipe design will therefore be conducted by a Designer appointed under CDM Regulations, assessed for the necessary competence.

General guidance on design and material selection can be found in EIGA IGC Doc 13/12/E, although UK practice has tended to be somewhat more conservative than this international document allows, especially for carbon-steel pipe materials.

The advice provided in this section assumes that all items are adequately oxygen clean.

The three main and inter-related features to consider and manage as part of the design process (for new build of modification/extension to existing) are:

- Management of adiabatic compression
- Management of flow-stream velocity and
- Variations in fluid flow

The last of these, variation in flow, is the most difficult to manage by the designer, as the flow and operational parameters for the system are likely to be set by external constraints. For oxygen safety, a steady flow rate is ideal. Sudden changes to the flow rate (increase or decrease) can be problematic for a variety of reasons. Extreme cases, i.e. completely halting the flow, or progressing immediately to high flow rates, are particularly problematic and may result in oxygen ignition. Reverse flow must be avoided in all cases. Any changes to flow conditions (where changes are necessary) should be managed such that they are slow and gradual, and the rate of change shall

Reference	Page	Issue No.	Revision No.	Date
UKS Oxygen COP	10	1	2	16/04/19

be minimized. Valves, for example, shall be slow-acting by design, to prevent over-zealous and fast operation. Other than sympathetic operational procedures (included in operation instructions, etc.), little else can be done to manage this problem. However, by approaching the other two features in an increasingly conservative manner, hazards can be managed.

Adiabatic compression is a common cause of oxygen ignition. Adiabatic compression can be minimised in operation (e.g. through the use of slow-acting valves, the use of by-passes at start/shut-down events, etc.) but is mainly addressed through good system design. Design features may be adopted such as:

- Always avoiding ‘dead ends’ or ‘dead legs’ on pipe systems
- Using distance pieces or heat sinks to help disperse the heat of compression
- Using the material of the pipe itself to dissipate heat of compression
- Minimization of mechanical friction, through the management of fluid velocity (see below)

The minimization of friction through the management of fluid velocity is the most complex feature to address.

Friction will be generated by the flow of the oxygen (pipe-wall friction) and this is dependent on the flow velocity. A lower velocity results in lower friction. EIGA IGC Doc 13/12/E provides guidance on acceptable velocities, but the point has already been made that UK practice is generally more conservative and so the EIGA limits should be regarded as absolute ‘never exceed in any circumstances’ maxima rather than as a design intent.

Friction and heat build-up will substantially increase wherever there are protrusions into the flow stream. Consequently any such protrusions should be carefully avoided through design, or else pipe velocity must be reduced to compensate. Components, fittings, tappings etc should be arranged to be absolutely flush with the inner pipe surface, to avoid any protrusion. Examples of items with potential to create protrusions are:

- Flange gaskets (if not exactly the right size, and/or if not accurately fitted)
- Instrument, sample, by-pass or control tappings
- Misaligned pipe sections and fittings
- Bolts and other fasteners
- Probes
- Branch connections, Y-pieces, etc.
- Fittings and accessories which are not full-pipe-bore (e.g. certain types of valve)
- Fitting and accessory components, e.g. non-return flap elements, meter vanes, etc.

Friction is substantially increased where small particles are conveyed in the flow stream. Particles (e.g. fabrication debris, corrosion, coating particles, dislodged surface impurities, carelessly applied sealants and tapes, etc.) will impinge on pipe surfaces, particularly on bends, valves, eddies, changes of section or direction and on any protrusions and may lead to localised heat build-up and potential ignition. Ignition may result in a major event due to a Kindling Chain. Friction minimisation is managed firstly by preventing particles entering the pipe system and flow stream and secondly by ensuring that any build-up of particles is removed before it creates a hazard. Good design, as outlined above, will ensure that protrusions are eliminated or at least strictly minimised along with a limited flow velocity. Design should consider long radius pipe bends which minimise friction.

Particulate generated during day-to-day operation of the mains can be managed through the inclusion of in-line filters. Filter must be of oxygen-compatible material (confirmed by the supplier or manufacturer) as filters are specifically designed for impingement. Sintered filters are now the most common type. Filters should be accessible and should be periodically checked for condition and remove any trapped debris.

Reference	Page	Issue No.	Revision No.	Date
UKS Oxygen COP	11	1	2	16/04/19

Particulate management should also be managed by a purge or blast-through:

- Immediately prior to commissioning and re-commissioning of the system
- Following intrusive maintenance, modification or extension
- Following an obvious particle-generating event such as a seismic event, vehicle impact, crane or crane-load impact, etc.

The purge is carried out by removing valve-heads, filters or other features to create a clear flow-path for debris to be discharged to the outside environment. Equipment that may be sensitive to debris damage should also be removed or protected (safety relief valves, regulators, instruments, capillary tubes, soft-seat valves, etc). Arrangements should be made to ensure debris is discharged safely, without endangering personnel or nearby equipment – also consider noise levels. A typical purge will last 10-15 minutes, or until the flow stream runs clear with no further particulate. Each system leg should be purged in turn. Carefully consider the fluid to be used for the purge:

- nitrogen is the preferred gas for purge applications. Other inert gases may be used, but potential asphyxiation hazards must be managed as the fluid is discharged from the system.
- air may be considered if a suitable source is available. Any air used must be oil and moisture free.
- oxygen may be considered (but the resulting oxygen-enrichment outside of the pipe system must be suitably managed, and the potential for ignition within the pipe is always present). Oxygen may be convenient to source, but is generally the least safe medium of the options described.

Depending on pipe integrity and rating, a purge of between 0.3 and 0.5 bar is usually adequate.

In view of the number of safety hazards requiring management prior to and during the purge, a formal written procedure or safe system of work is mandatory.

Pipe Material Selection

EIGA IGC Doc 13/12/E contains guidance on oxygen compatible materials.

Components shall be suitable for use in oxygen service, as declared by the manufacturer or supplier, and preferably declared as such in writing and managed in line with a suitably accredited QA system.

Pipe material itself is worthy of specific comment:

Carbon Steel – this material was used historically for oxygen pipe but is rarely used nowadays except for carefully-managed modifications to existing systems. The material is prone to particle generation through corrosion, and this results in an unsatisfactory performance unless particulate is very carefully managed in line with the requirements above. It performs indifferently in respect of adiabatic compression. Carbon steel is considered satisfactory only for steady flow conditions, with a carefully limited flow velocity.

Stainless Steel – this material is commonly used, especially for larger diameter pipes (although it may still be economic at smaller diameters). Note that thin-walled stainless may perform better with adiabatic heat dissipation than thicker-walled alternatives. Welded systems are also readily ‘CE’ marked under the Pressure Equipment (Safety) Regulations, where this is a requirement.

Copper and Cupro-nickel – this material is commonly used, especially for small diameter pipes. It has the best performance in terms of managing adiabatic compression and is less prone to particle generation than ferrous materials. The material is unlikely to be economically viable at larger diameters. Under the Pressure Equipment (Safety) Regulations, pipes can be CE marked with suitable materials management QA, and smaller-bore systems may be designated as ‘SEP’ (Sound Engineering Practice), potentially minimizing supporting QA activity.

Brass, nickel, Inconel 600 (no other varieties), Monel, Hastelloy, beryllium-copper – these materials are acknowledged as oxygen-compatible, but due to economics are not viable for pipe material. However, they may be encountered within smaller specialist components in valves, instruments and other accessories, particularly filters.

Reference	Page	Issue No.	Revision No.	Date
UKS Oxygen COP	12	1	2	16/04/19

6.3 Non Metallic Materials

The advice provided in this section assumes that all items are adequately oxygen clean.

Materials for use with oxygen streams should exhibit:

- a high oxygen index (a measure of the material's ability to sustain candle like burning),
- low heats of combustion value,
- a high Auto Ignition Temperature (AIT),
- good aging properties to avoid long term oxidation

If cleaning solvents are used, ensure that the solvent will not adversely affect the material at a chemical level, both at the point of application and when in the oxygen environment. Good practice and manufacturer's instructions should be followed to ensure that solvents are suitably removed, dried, etc. prior to the component being installed.

Insulating material used in flanged insulating joints between above ground and below ground piping, shall have a dielectric strength in the order of 10 kV/mm thickness.

Ultimately the qualification of vendor products should be checked for suitability for oxygen use, based on the specific pressure and flow conditions.

Oxygen compatible sealant tape (in accordance with BS EN 751-3) should be applied to the threaded portion only, and stepped back from fitting faces so that it does not enter the oxygen flow stream.

7 - DESIGN

The system shall be designed so that pigging can be used for internal cleaning of the pipework.

ABOVE GROUND PIPING SYSTEMS

7.1 Isolation Facilities

A risk assessment should be undertaken to determine the design of isolation, E.G. Double block and bleed, single block and bleed, etc.

Isolation valves should be installed for shut down and maintenance of sections and plant items shall be identified at design stage. Valves used shall be gate, ball, plug or butterfly type.

Specific considerations relating to each valve type can be found in The EIGA Standard IGC Doc 13/12/E, Section 5.3.3 "Valve Types". Quick opening valves, such as ball or butterfly type, have inherent risks when recharging the system.

An isolation valve shall not be opened if a pressure difference exists across it, due to the creation of excessive gas velocity, and the danger that incurs. Consideration shall be given to the provision of isolating valves with a pressure equalisation or by-pass arrangement including both upstream and downstream pressure gauges so as to ensure the safe pressurisation of the downstream pipework.

The factors that determine the necessity of such an arrangement are:

- (a) The pressure of the oxygen in the pipe upstream of the isolating valve.
- (b) The capacity of the pipe downstream of the isolating valve.
- (c) The design and means of controlling the isolation valve.

The pressure equalisation or bypass arrangement shall be designed to ensure the safe re-entry of oxygen into the pipework, e.g. copper lining of the branch connection. The valve and pipe work shall be in copper or copper alloy. The by-pass valve shall be of the globe type. The by-pass piping shall tee into the main pipework above the main line centre line to avoid a dirt trap.

Where bypass is impracticable, downstream re-pressurisation with nitrogen, prior to the introduction of oxygen, shall be facilitated within the system design.

Note: A procedure should be established for the operation of each main isolating valve and that each isolating valve be identified by number, which should be used for reference purposes. Such procedures should form part of any emergency planning.

Reference	Page	Issue No.	Revision No.	Date
UKS Oxygen COP	13	1	2	16/04/19

7.2 Throttling or Process Control Valves

Throttling duty is considered the most severe class of valve duty. These are generally globe, modified ball, eccentric plug or butterfly type, although generally butterfly valves do not have a good flow/pressure drop characteristic unless specially shaped. Specific considerations relating to each valve type is stated in The EIGA Standard IGC Doc 13/12/E, Section 5.3.3 "Valve Types". Material selection is of paramount importance. Reference is made to the potential for high velocity and turbulent impingement flow for up to 10 pipe diameters downstream of the valve.6.3
Emergency Shut Off Valves

These are high flow valves, being gate, knife gate, and butterfly or ball type. It should be noted that as a valve closes in an emergency it will be subject to the same conditions as a process control valve and hence material selection is just as important.

7.3 Filters

Filters shall be provided upstream of a copper pipe system which is preceded by a steel pipe section, e.g. a distribution centre, in order to prevent particulate entering copper pipework which is likely to be running at a high velocity.

Consideration shall be given for the provision of filters upstream of:

- (a) Components having soft seatings which are vulnerable to damage e.g. pressure regulators, control valves.
- (b) Components that have moving parts in contact with the oxygen stream e.g. flow measuring devices.

Filter elements shall be fit for purpose at the design conditions. The mesh of a filter is regarded as high risk, with high velocities experienced across it, the mesh experiencing direct impingement when trapping particles. Appropriate materials such as nickel, bronze or Monel 400, or sintered nickel must be used, and pressure differential measuring equipment across the filter shall be provided.

The filter element must be selected to withstand the maximum differential pressure across it, namely the maximum operating pressure to atmospheric pressure or downstream vacuum pulled, which can occur when fully blinded, so as not to buckle or collapse.

Isolation valves should be provided to enable easy filter removal for cleaning, and a vent valve installed after the filter, but before the downstream isolation valve. Safe re-pressurisation of the system shall be considered. Impulse piping and valves to facilitate back blowing shall not be allowed.

7.4 Flow Measuring Devices

Static meters such as orifice plates are preferred over moving element meters if required. Manual block and bypass valves should be located away from the measuring element, away for potential fire areas.

Design considerations for flow-measuring devices are listed in EIGA-IGC Doc 13/12/E, Section 5.4.4

7.5 Protection Systems

The design of protection systems using flow, pressure, temperature switches etc. should take into account the following factors:

- how critical the supply reliability must be,
- the quality and reliability of devices,
- likelihood of failure events, such as power failure, instrument air failure, instrument circuit failure, and the risks these failures could cause,
- the ability of the operator to respond to alarms only, or use alarms and trip logic in operator absence.
- In all instances the system should be designed to fail to a safe condition

Reference	Page	Issue No.	Revision No.	Date
UKS Oxygen COP	14	1	2	16/04/19

7.6 Pressure Relief

Pressure relief devices shall be installed to protect the integrity of the system and equipment. Unless the system downstream of each pressure reducing valve is capable of safely taking the full applied upstream pressure, relief valves shall be fitted, capable of discharging either:

- (a) 100% of the full oxygen flow or
- (b) The nominal leakage resulting from a seat failure in the reducing valve and in conjunction with bursting discs be capable of discharging 100% of the full oxygen flow.

Full oxygen flow shall be the maximum oxygen flow rate with all valves failed in the wide-open position and with maximum upstream pressure. Relief valves should be positioned sufficiently close to the pipework so that the pressure drop across the inlet connection does not allow the valve to close before the correct pressure condition is restored in the pipework. The exhaust from the relief valve to atmosphere shall also be considered in the overall system design to ensure that the backpressure of the venting system at the design flow does not effectively increase the operating pressure of the relief valve operation.

The flow through relief valves, due to the gas pressure differential across the valve, is typically under supersonic conditions. The noise generated from the relieving activity shall be considered and managed in the venting system design.

Bursting discs may also be fitted to provide an extra layer of protection. Exhaust from these devices shall be suitable risk assessed and located for safe venting.

The selected pressure set points for the relief devices needs to be carefully considered in an oxygen system design. The tolerances for both relief valves and bursting discs needs to be considered to avoid unnecessary relief activities and still provide adequate system protection. The upper threshold (set point + upper tolerance) for any device (and associated relief piping) shall not exceed the maximum allowable working pressure, and when both relief valves and bursting discs are fitted to a system, the upper threshold of the relief valve shall be less than the lower threshold (set point-lower tolerance) of a bursting disc.

It is good practice for all relieving devices to be paired identically, with both upstream and downstream (assuming common vent manifold) manual, lockable isolation valves, and vent valves as required. This gives the opportunity to remove, test, and reinstall valves in situ while safely operating the oxygen system, and also allows bursting discs to be replaced in situ safely as required.

The design shall ensure all gases are vented to a safe area with adequate provisions in place in order to prevent people from entering the area.

7.7 Vent Lines

Oxygen shall be discharged into a safe area. The position of the discharge end of the vent line shall be into an area so as not to create further hazards.

Where fitted vent lines shall be in copper. They shall be securely anchored to resist the thrust of venting oxygen. The discharge end of the vent shall be constructed to minimise the ingress of foreign matter.

Where manual vents are fitted to reduce system pressure in an emergency the vent valve, which should be of a copper alloy particularly the internals, should be sized to ensure that the resultant velocity in any of the system steel pipework will not exceed the recommended level.

Manual vent and drain lines should be provided to allow appropriate immobilisation, but shall be kept at a minimum to reduce the potential for leaks.

7.8 Line Valves for Portable Equipment

Line valves for connection to hoses for portable equipment should be fitted with a suitable self-sealing device. A self-sealing adapter is shown in Appendix E.

Permanent flexible connections, hoses, and expansion joints shall not be used.

Reference	Page	Issue No.	Revision No.	Date
UKS Oxygen COP	15	1	2	16/04/19

7.9 Dust Traps & Dead Pipework

Dust Traps and Dead pipe work shall be avoided by design with connections made above the pipework centreline, or horizontally worst case. Avoid enlarged tees, non-flush gaskets, and standby lines being positioned below the main line, and sudden changes in pipework diameter such that particles will not drop out under reduced velocities.

7.10 Electrical Continuity

In above ground sections the designer shall ensure electrical continuity and earthing of the pipework particularly with reference to flanged joints so as to avoid the build-up of static charges and provide protection against damage from lightning. The electrical resistance to earth shall be as specified in BS 7671, BS 7430, and BS EN 62035

7.11 Insulating Joints

Insulating joints shall be used to provide permanent electrical discontinuity between Pipework that have cathodic protection, and those that do not. The insulating material shall have good dielectric properties as given in Section 6.3.

Insulating flange joints should be placed horizontally (i.e. in vertical Pipework) to avoid the build-up of bridging dirt and moisture between the flanges.

7.12 Expansion Loops

Where a wide variance of atmospheric temperature is expected, expansion loops shall be used, and their radius of curvature should be such that cleaning by pigging can be used if required.

7.13 Flexible Connections

These should be avoided where possible, expansion loops are the preferred option where practicable. Where flexible connections are required as between platforms and plant subject to movement or vibration they must be of a suitable material and manufactured to a suitable standard in accordance with ISO 3821. Dust entrapment areas should be avoided where possible.

7.14 Noise Reduction Devices

Noise reduction devices may be retrospectively installed, if required. They should be constructed entirely of metallic and/or concrete materials. Materials shall be corrosion resistant and in line with Impingement velocity curve Fig 1. Sound absorbing material shall be non-combustible, free of grease, made of glass fibre or mineral wool.

7.15 Other Accessories

If instrument piping is small bore, and used in a "non-flow" application, then stainless steel tube shall be used.

Dial gauges shall be provided with rear blow out plugs or bursting discs. Safety glass shall be used.

All instruments used to measure or monitor oxygen systems shall be compatible with oxygen.

7.16 Lubricants

Oxygen systems shall be designed to operate without lubricants.

Where this cannot be complied with, information relating to lubricants is available in the EIGA Standard IGC Doc 13/12/E, section 5.5.

7.17 Location of Pipework Away from Hazards

Oxygen Pipework should wherever possible be located away from other hazardous materials, i.e. flammable materials, liquids and gases, sources of heat, sources of vibration and electric power lines. Where this is not possible suitable precautions shall be taken to protect the pipework. The temperature of the wall of a pipe containing oxygen shall not be allowed to exceed 100 degrees centigrade.

Any mechanical joints used within this pipework shall be staggered with joints in other hazardous Pipework. Where practicable all joints should be welded rather than flanged. Welded joints reduce risk of leaks from the system.

Oxygen Pipework shall be located away from electric cables where a high flux may give rise to eddy currents in the pipe which may cause hot spots and hence the danger of ignition.

Reference	Page	Issue No.	Revision No.	Date
UKS Oxygen COP	16	1	2	16/04/19

7.18 Risk of Ignition from Arcing in Electrical Apparatus

Electrical and oxygen outlet equipment shall be positioned as far apart as possible. A risk assessment should be carried out in accordance with DSEAR (see page 7).

7.19 Pipework Supports

Pipework shall be adequately supported and secured to prevent

- sagging in the pipe beyond safe limits
- transmission of stresses to connected equipment, e.g. valves etc.
- excessive local stresses in pipes

A schedule of periodic inspections shall be maintained.

7.20 Identification of Pipework

New oxygen Pipework above ground and existing Pipework above ground when repainted shall be identified in accordance with BS 1710.

The word 'OXYGEN' shall be superimposed on the identification colour on the pipe or on a suitable label attached to the pipe in black letters and in a position that shall be clearly seen at all junctions, at each side of valves, service appliances, bulkheads, wall penetrations, at any other place where necessary and at regular intervals along the pipe at distances not exceeding 16 m apart. Direction of flow banding should also be incorporated.

Consideration should also be given to specifically identifying valves in accordance with local works practices.

7.21 Compounds

In any compound containing an oxygen system, the floor shall be level and well drained. Two suitably positioned exits shall be provided for use in emergency. The compound shall normally be kept locked and provided with adequate lighting in accordance with DSEAR.

7.22 Gas Control & Metering Stations

See Appendix C

7.23 Painting

Above ground piping shall be prepared for corrosion protection painting and colour coding for identification.

Further references are to be found in:-

ISO 8501-1 "Preparation of steel substrates before application of paints and related products, visual assessment of surface cleanliness part 1." Appendix G 6.17 to 6.20 for painting specifications.

8. ADDITIONAL DESIGN REQUIREMENTS FOR UNDERGROUND PIPEWORK

Underground pipework shall be of welded construction to API1104 or other equivalent codes.

External coating for underground pipework can be carried out before or after internal cleaning is performed as long as precautions are taken to ensure that the external coating process does not compromise the cleanliness standard of the internal surfaces.

Flanged joints shall NOT be used on underground piping or in pits.

Underground piping shall be electrically isolated from above ground piping and other metal structures.

8.1 Pipework in Ducts

Oxygen pipework should not be run in ducts or tunnels containing other piped flammable liquids or gases, electric power cables, or where oxygen leakage may contact oil. Where oxygen and flammable gas pipework must be contained in the same duct or tunnel, adequate ventilation shall be provided.

8.2 Pipework in Filled Trenches

Pipework in filled trenches shall be buried to provide a cover of at least 800 mm. Pipework shall be evenly bedded throughout their length. Where the trench is excavated in rock a well rammed bed of sand or earth of at least 140 mm depth shall be provided for the pipe.

Reference	Page	Issue No.	Revision No.	Date
UKS Oxygen COP	17	1	2	16/04/19

The best of the excavated material, which shall not include surface material, vegetable growth, contaminated earth or large stones, shall be returned to the sides of the pipe and to provide a cover of 250 mm. This shall be thoroughly compacted by mechanical means. The remaining excavated material shall be returned to the trench in layers of 250 mm and each layer thoroughly compacted by mechanical means.

External surfaces of pipework containing flammable liquids or gas in filled trenches shall not be less than 450 mm apart. Where pipework are encased in concrete the minimum distance apart may be reduced to 300 mm.

8.3 Pipework Under Roads and Railways

Oxygen pipework under roads and railways shall be buried to provide a minimum cover of 1.4 m. The pipework shall be protected from vibration and impact loads by either encasing in concrete, which shall not be less than 160 mm thick or suitably supported in a larger steel pipe. The protection shall extend not less than 1 m either side of the road or railway.

Consideration shall be given for the provision of isolating valves at one or both sides of pipework under road or railway crossings whether they are internal or public crossings.

8.4 Pipework Adjacent to Existing Services

Where pipework are required to pass under or near existing services operated by other public or private authorities, plans of the relevant pipework system shall be submitted to and agreed with the appropriate authority.

8.5 Underground Valves

Underground valves are to be avoided. If this is not possible they shall be situated in an adequately drained valve chamber suitably vented and with access for operation and maintenance. Consideration should be given to protection from unauthorised or malicious operation.

8.6 Identification of Underground Pipework

8.6.1 Pipework in Filled Trenches

Oxygen pipework in filled trenches shall be identified by means of a PVC tape or other suitable material. The tape shall be continuously laid in the trench during the backfilling operation at about 300 mm below the surface. The colour of the tape shall be yellow ochre in accordance with BS 4800 colour reference 08 C 35.

The words 'OXYGEN PIPEWORK' shall be clearly and permanently marked on the tape in black letters at not more than 1 m intervals.

8.6.2 Surface Markers

Surface markers shall be provided to show the path and changes in direction of underground pipework. The markers should be clearly and permanently inscribed with the words 'WARNING OXYGEN PIPEWORK' together with the name of the pipework operator and telephone number of the person to be contacted in an emergency. Consideration should be given to the use of electronically detectable marker tape or wire.

Accurate records shall be maintained showing routes of all underground oxygen pipework.

8.7 Corrosion Protection

Oxygen Pipework below ground shall be protected and suitably protected.

A competent person shall be consulted to determine whether cathodic protection is required to suit local requirements.

Further information is available in: BS EN 13636:2004 BS EN 15112:2006

Note: CP 2010 Part 2 gives information concerning the design of pipework crossings of roads, railways and watercourses and information concerning cathodic protection.

8.8 Specialized surveys

In addition to the routine monitoring of the cathodic protection system potentials, a Close Interval Potential Survey (CIPS) should be performed at 5 year intervals, and implementation of an integrity management program on the pipework should be performed in accordance with applicable regulations.

Reference	Page	Issue No.	Revision No.	Date
UKS Oxygen COP	18	1	2	16/04/19

Problems with cathodic protection systems for the pipework identified by annual surveys, close interval surveys, or other means, may be diagnosed using a variety of techniques, such as:

- close interval potential survey
- alternating current voltage gradient (ACVG) survey or direct current voltage gradient (DCVG) survey
- current attenuation survey / pipework current mapping survey (PCM)
- Pearson survey

A full list of above ground survey techniques can be found in NACE SP 0502, Standard Practice - Pipework External Corrosion Direct Assessment Methodology [50]. These indirect inspection techniques may be applied as an integral part of a pipework integrity management programme - close interval potential survey;

9. CLEANING & FABRICATION

A written procedure shall be prepared to detail how cleanliness of pipework systems shall be guaranteed at the point of commissioning. A combination of procedures shall be used to maintain delivered goods clean, to clean post fabrication, and clean post installation.

The EIGA Standard IGC Doc 13/12/E lists cleaning methods, and provides information on available pig types

9.1 Cleaning Prior to Fabrication

Pipes, valves, components and fittings for use in oxygen systems must be suitably cleaned by a specialist company before fabrication and/or assembly in the pipework system.

9.1.1 Cleaning Steel Pipes and Fittings (excluding stainless steel)

Unless otherwise specified, steel pipes and fittings shall be cleaned by:

- (a) Degreasing if necessary.
- (b) Abrasive cleaning.
- (c) Acid pickling.
- (d) Passivation.
- (e) Hot water wash.

Stainless steel wire brushing should be used for abrasive cleaning. Shot or grit blasting should be avoided where possible, but if used, special care shall be taken to ensure that all shot particles are removed. After cleaning, all parts shall be dried either naturally or, if necessary by air blown from a fan. Care must be taken to avoid transfer of dust into the pipework.

9.1.2 Cleaning Copper Pipe and Fittings

Copper pipe and fittings shall be degreased and all traces of degreasing agent allowed to evaporate assisted, if necessary, by clean air blown from a fan. Care must be taken to avoid transfer of dust into the pipework.

9.1.3 Cleaning Valves and Other Components

Unless a component is received as 'Oxygen Clean', then it shall be dismantled, each part identified and then degreased. All traces of degreasing agents shall be removed and the clean dry parts reassembled. Where any part requires replacement, e.g. gland packings, parts from the same material and specification shall be used.

9.1.4 Clean Work Area

Cleaning, reassembly and packaging of valves and components shall be carried out in a clean work area. The clean work area shall have adequate ventilation to prevent build-up of degreasing agent vapour above the permitted threshold limit value (see Appendix B). Tools shall be maintained in a grease-free condition.

Reference	Page	Issue No.	Revision No.	Date
UKS Oxygen COP	19	1	2	16/04/19

9.1.5 Inspection & Protection

Pipes, valves, components and fittings after cleaning and inspection shall be immediately and adequately protected against corrosion and the ingress of contaminants. Pipe ends and other openings shall be securely sealed using purpose made plastic caps or suitable alternative capping.

Valves and other components shall be securely packed in polythene bags or other suitable container and labelled. 'DEGREASED FOR OXYGEN SERVICE'

Particular attention should be paid to large valves and components to ensure that the flanges are adequately and securely protected and will remain so during subsequent handling.

See paragraph 8.3.5 for information on inspection for cleanliness.

A suggested scheme for a cleaning procedure is shown below in Fig. 1.

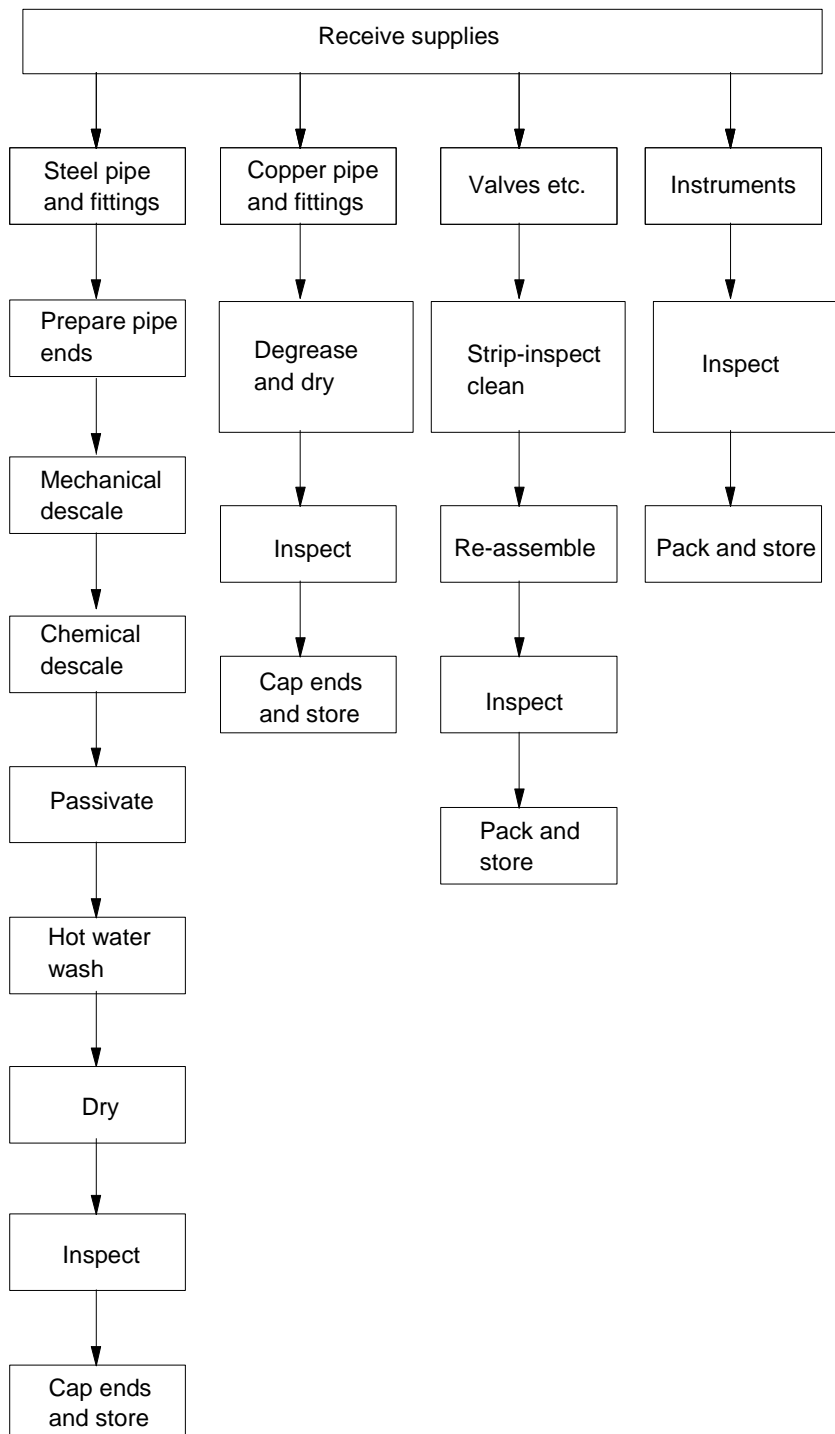

Fig. 1 PRE-FABRICATION AND CLEANING PROCEDURE

Reference	Page	Issue No.	Revision No.	Date
UKS Oxygen COP	20	1	2	16/04/19

9.2 Fabrication

9.2.1 General

Fabrication of oxygen Pipework shall be generally in accordance with ISO 3834. And in general follow the plan given in Fig 2, page 26.

Welding shall, wherever possible, be done under a quality controlled environment. Site welds should be kept to a minimum. Weld penetration shall be complete but shall give a minimum of projection and scaling in the pipe bore. Where the back of a butt weld is inaccessible for dressing and de-scaling, inert gas shield arc welding should be used for the root run. Backing rings and strips shall not be used.

Commercially available butt-welding steel fittings should be used for the fabrication of tee-pieces and branches. Where oxygen flow is unidirectional swept tee-pieces should be used.

Note: ISO 3834 requires that, with certain amendments, welding shall be Class 1 quality in accordance with BS 2633.

The required weld surface finish can be achieved by using welding systems outlined in The EIGA Standard IGC Doc 13, Section 7.3.1.

Valves that are to be welded into Pipework shall be open and if necessary the valve's top work parts removed to avoid heat/fume damage of soft parts.

9.2.2 Bends in Steel Pipe

Bends in steel pipe to be cleaned by pigging shall preferably have a radius of ten times the nominal diameter of the pipe, but a minimum of five times.

Bends shall not have any corrugations, notches or sharp changes in direction.

Bends shall be gauged before use and constriction rectified.

9.2.3 Copper Pipes and Fittings

Fittings in copper or copper alloy shall be either inert gas shield welded, brazed in accordance with ASME Section IX and BS EN 13134 or silver soldered.

9.2.4 Non-Destructive Examination

Butt-welded joints shall be examined radiographically or by other suitable techniques in accordance with BS EN ISO 17636.

Final closing welds shall be subject to 100% X-ray examination in which case pressure testing may be unnecessary.

Socket and fillet welds should be tested with X-ray or other suitable non-destructive testing method, such as dye-penetrant tests.

Where radiological hazards are not acceptable, 100% ultrasonic examination by qualified operator, with a specific report on each weld, shall be carried out. When pipe wall thickness is less than 8mm, ultra-sonic testing is not suitable and alternative jointing or non-destructive test methods should be used.

The number of joints examined may be reduced as appropriate for individual welders after initial satisfactory results have been produced.

9.2.5 Gaskets

Gaskets shall be made from material compatible and approved for oxygen service. Gaskets to be machine cut and be correctly sized to ensure that no part of the gasket projects beyond the inner wall of the pipe into the gas stream. The use of gasket sealants is prohibited. The re-use of any gasket is prohibited. A new gasket will be inserted each time a flanged joint is released.

9.2.6 Pressure Testing of Fabricated Pipework

The preferred option is a pneumatic pressure strength test using dry, oil free air or nitrogen, keeping the pipework free from moisture and contaminants. In this case, hydrostatic pressure testing is not practicable. However, if the pipework is in an area which can't be cleared of

Reference	Page	Issue No.	Revision No.	Date
UKS Oxygen COP	21	1	2	16/04/19

personnel, or pneumatic testing is considered unsafe for any reason, then a hydrostatic pressure test using water with de-oxygenation and passivation agents added shall be employed. Water should be immediately drained following the test, and the piece dried with dry oil-free air or nitrogen (-30°C dew point or better). Tests shall be in accordance with national codes such as EN 10208-2 or API 5L.

9.2.7 Quality Inspection

An inspection of the fabrication for quality should follow the relevant piping codes and procedures, and as a minimum should include:-

- pipe concentricity
- protective coating integrity
- mechanical imperfections
- weld quality
- review of X-ray examination documentation

9.3. Cleaning Pipe Fabrications & Pipework Systems Before & After Final Installation.

See Fig 2, Page 26

9.3.1 Cleaning by Pigging

Wherever possible, pipe fabrications and completed systems shall be cleaned by 'pigging'.

Pipe fabrications should, before erection, have a gauging pig and a scraping pig passed through.

Erected pipework systems shall be prepared and cleaned as follows:

- (a) Valves and other line fittings shall be removed, connections blanked off and spool pieces fitted as necessary.
- (b) A foam and brush pig shall be passed through the system and inspected for damage to ascertain anomalies in the pipework.
- (c) Further pigging shall then be determined by the competent person.

After cleaning in accordance with (b) and (c) the pipework shall be further cleaned, depending on the extent of the contamination, by either:

- (d) Passing a foam pig adequately charged with degreasing agent, through the pipework to remove oils and small particles of foreign matter.

The operation shall be repeated as long as the foam pig continues to pick up foreign matter as determined by careful examination under ultra violet light.

and/or

- (e) Passing a slug of degreasing agent through the pipework.

Note: BS CP 2010 Part 1 and EIGA Document 13 contain information concerning pigging.

9.3.2 Where Pigging is Impracticable

Where cleaning by pigging is impracticable, e.g. size limitation, extreme care shall be taken to ensure that pipes are clean before fabrication in accordance with Section 9.1, welded joints are made in accordance with Section 9.2 and adequately protected so as to maintain the pipe in a clean condition suitable for oxygen use (see EIGA Document 33). Welding shield gas for pipework purge shall be carried out prior to welding.

Where the completed pipework has been contaminated by either oil or grease a degreasing agent shall be passed through the pipe at full bore flow.

9.3.3 Removal of Degreasing Agents

Where degreasing agents have been used as in Section 9.3.1 (e), 9.3.1 (f) or 9.3.2 extreme care shall be taken to ensure that all traces of degreasing agent are removed. Low points in the pipework shall be drained and other trapping points stripped, drained and thoroughly dried.

Reference	Page	Issue No.	Revision No.	Date
UKS Oxygen COP	22	1	2	16/04/19

Note:

1. Chlorinated hydrocarbon degreasing agents are combustible in oxygen and have caused severe explosions when the degreasing agent has not been removed from the system.
2. Equipment suitable for the detection of degreasing agents is commercially available. A competent authority should be consulted upon the choice of equipment.
3. Attention is drawn to the fact that build-up of toxic levels of degreasing fluid vapours can easily occur unless adequate ventilation is provided. See appendix B.

9.3.4 Blowing out of Pipework

Before pressure testing and commissioning, new Pipework should be blown out using, dry nitrogen or dry air to remove loose debris. The velocity of the nitrogen should be substantially in excess of the design maximum for oxygen operation. Blow-out aims to achieve, a minimum requirement, a surface finish in accordance with ISO 8501-1.

All soft-seated valves should either be removed or isolated to prevent damage. Filters should be either removed or inspected and cleaned afterwards.

If the system is not complete then any openings should be capped following the blow out.

In the event that sections of pipework are fabricated and stored or a partially complete system is capped off for a period and internal surfaces may deteriorate, then the cleaning and blowout operation should be repeated following completion of the system as described above **before** final pressure testing and commissioning.

9.3.5 Cleanliness Inspection (Supplied Equipment)

Equipment supplied for use in oxygen service must comply with the user specified cleanliness requirements. The manufacturer must demonstrate that their processes are controlled and operated under a set of detailed quality control procedures and standards that meet the user's requirements. Cleanliness to be in accordance with EIGA Document 33.

9.3.6. Cleanliness Inspection

Where inspection for cleanliness is necessary at any stage, the appropriate method of testing and procedure should be carried out in accordance with appropriate guidance in EIGA Doc. 13 Oxygen Pipeline and Piping Systems and Doc. 33 Cleaning of Equipment for Oxygen Service.

9.3.7 Detection Limits

The results of measurements depend in a physical and optical way on the contaminating agent e.g. type of oil or grease. This is the reason for the wide range of the detection limits given in the table below. The quoted ranges are for information only

Test method	Informative threshold of detection mg/m ²
Bright white light	500 - 1700
UV light	40 - 1500
Wipe test	30 - 600
Water break test	30 - 60
TOC, solvent extraction	< 10

Table 1 - Detection limits for test equipment

A combination of test methods results in improved detection.

9.3.8 Acceptance Criteria

This section gives quantitative values for two pressure ranges.

Reference	Page	Issue No.	Revision No.	Date
UKS Oxygen COP	23	1	2	16/04/19

The pressure strongly influences the ability of the contaminant to ignite. Contaminants are foreign unwanted matter that can have a negative effect on system operation life or reliability. They are mainly:

- a) Oils greases and detergents
- b) Other foreign matter (solid particles, dust layers, liquids) being either
 - Organic substances e.g. wood, paper, cloth, plastics, rubber, adhesives, fibres, paints or anticorrosive, solvents or
 - Inorganic substances for instance metal chips, scale, weld splatter, welding rod remnants, rust particles, sand, water drops, or any other particles

Pressure Range Bar gauge	Oil, Grease, Detergents, organic coatings mg/m ²	Particles	Moisture
< 30	500 (1)	Single small chips or fibres can be tolerated	No drops of water visible
>30	200 (1)	Single very small chips or fibres can be tolerated	No drops of water visible

Table 2 - Maximum allowable quantities of foreign matters

1. The values are given considering a uniform distribution of the contamination at a max temperature of 70 °C.

The quoted figures should be considered as guidance only. Lower figures could be requested depending on the specific application (type and state of fluid, temperature, pressure, flow, velocity, product purity), or effects like migration.

Clusters of fibres other particles and dust i.e. relative high local concentrations, must not be visible.

Reference	Page	Issue No.	Revision No.	Date
UKS Oxygen COP	24	1	2	16/04/19

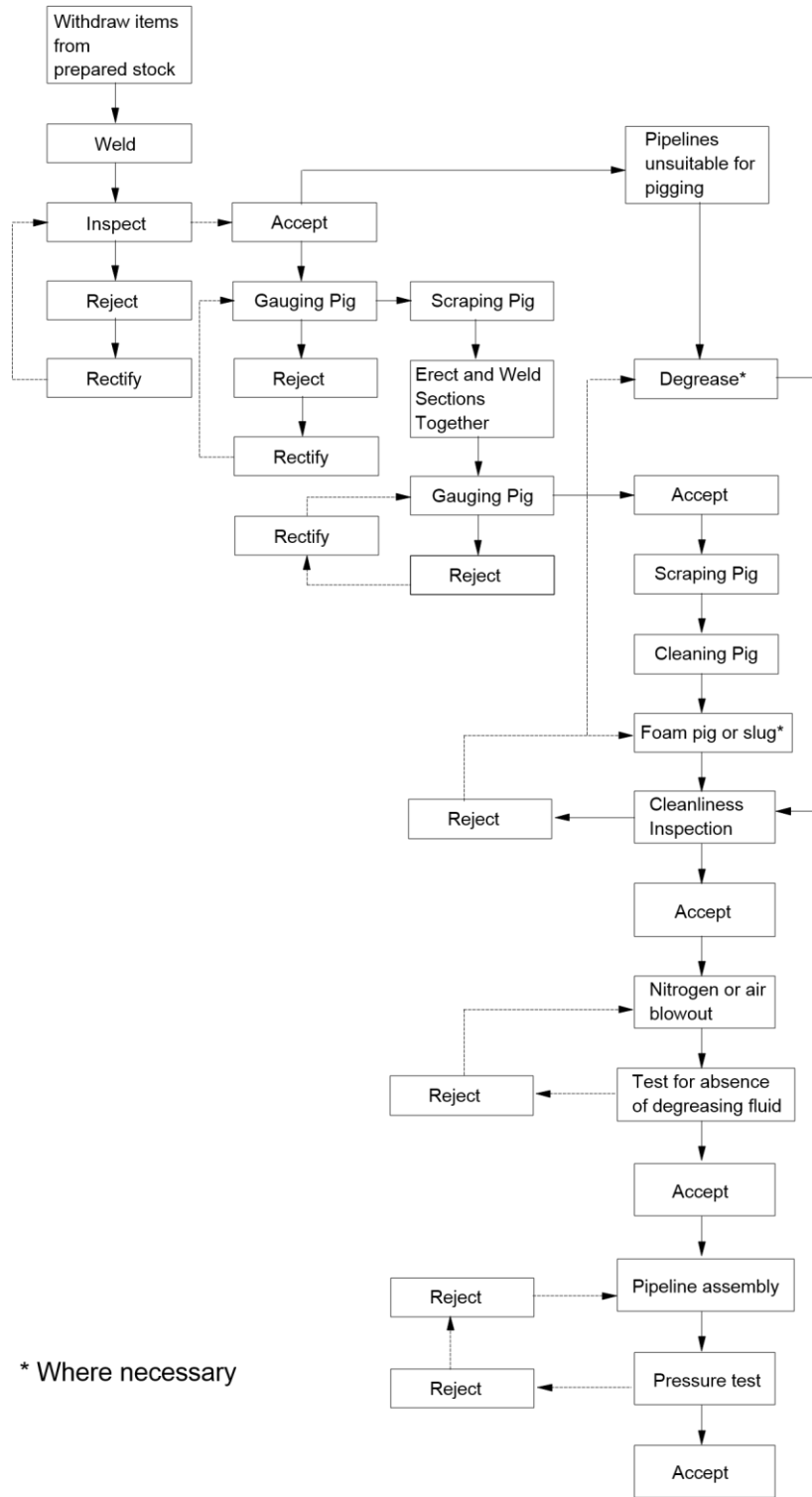

FIG. 2 SUGGESTED SCHEME FOR FABRICATION, ERECTION, CLEANING, INSPECTION AND TESTING OF PIPEWORK

Reference	Page	Issue No.	Revision No.	Date
UKS Oxygen COP	25	1	2	16/04/19

10. ASSEMBLY & INSTALLATION

10.1 Supports, Guides & Anchors

These shall be fit for purpose, positioned and secured as the design, prior to placement of the pipework.

All in-situ welded connections such as earthing-clamps and supports shall be connected to the pipework prior to pressure test commencement.

If cleanliness cannot be maintained during installation, then cleaning will be required as section 9.3

10.2 Pressure testing of the complete installed pipework/pipe system

10.2.1 General

Oxygen Pipework shall be pressure tested using clean dry oil free nitrogen or dry air. The pressure shall be increased gradually in steps providing sufficient time to equalise strains in the system.

If pneumatic testing is not practicable then hydraulic testing can be carried out, then the system must be subsequently dried to a dew point of less than minus 30°C. Only personnel involved in the testing shall be allowed in the immediate area of the pipework being tested.

10.2.2 Initial Leak Test

The purpose of initial leak testing is to identify and repair leaks before a system is placed under significant pressure. This practice reduces risk, and also saves time and costs associated with depressurising and re-pressurising systems in the event of finding a leak. For gases, most leaks are found at approximately 0.25bar.

Leak testing is carried out using the 'drop test' method, and in incremental stages no greater than 1 bar, with suggested initial pressures of 0.25 and then 0.5 bar. A "drop test" should be carried out over a period of 30 minutes. If there is no detectable fall in pressure proceed to the next stage. If a drop in pressure is detected, leak testing should be carried out using an approved leak test fluid which is compatible with the equipment that is being tested. EIGA Doc. 78 provides guidance. Other methods for finding leaks at low pressures, such as 'taping' between flanges is also acceptable, however all testing materials must be removed after pressure testing is completed.

The minimum final pressure of a leak test shall be pressurised to a minimum of 7 bars regardless of the system design. All leaks shall be rectified prior to progressing to further testing.

10.2.3 Proof Strength Test

The purpose of proof strength testing is a final check on the quality of manufacture and construction of the oxygen system.

Proof strength testing shall be set out in the pipework design. Typically proof testing can be as follows:

- (a) For design pressures up to and including 20 bar, the test pressure shall be 1.5 times the design pressure.
- (b) For design pressures up to and including 40 bar, the test pressure shall be 1.25 times the design pressure up to a maximum of 52 bar.

The test pressure shall be maintained for 30 minutes. Checks shall be made for any leaks, damage or movement not provided for in the design and any fault rectified.

10.2.4 Acceptance Test

The purpose of an acceptance test is to test for leaks over a longer period at a high pressure. This is particularly useful when leak testing for small leaks is impracticable. The exact parameters of the acceptance test are at the discretion of the competent person, with the following as a guide.

The pipework shall be tested by maintaining the test pressure at the maximum working pressure of the system plus 10% for not less than 24 hours. During this time the pressure drop shall not exceed 1.5% taking into account changes in ambient temperature. Where this pressure drop is exceeded it shall be construed as evidence of a leak.

Reference	Page	Issue No.	Revision No.	Date
UKS Oxygen COP	26	1	2	16/04/19

The test pressure shall be maintained as long as practicable in relation to the extent of the work being undertaken. In some circumstances the test can be restricted to the section of the system that has been modified. However, care must then be exercised when reconnecting to the rest of the system.

10.2.5 Delayed Commissioning

Delays in commissioning should be avoided. Where the commissioning of the pipework is delayed for any significant length of time or where a pipework has to be shutdown, then that pipework shall be filled with clean, dry oil-free nitrogen or dry air which shall be maintained at a slight positive pressure (100mbarg). The oxygen pipework shall be sealed to prevent the ingress of moisture. The holding pressure shall be monitored.

A significant length of time would normally be a period in excess of 16 days.

11. COMMISSIONING/DE-COMMISSIONING

All commissioning and de-commissioning shall be subject to a Safe Working Procedure and a risk assessment which will take into account such things as general location of vents vis-à-vis buildings, sources of ignition, competent personnel, gas monitoring and testing, copper fittings, tools and equipment as specified within this and associated documents.

11.1 Pre-Commissioning Checks

Checks will include:

- P&ID design to reality
- relevant material, cleaning, calibration, test certificates, and Operation & Maintenance manuals,
- warning notices, and instruction plates posted,
- satisfactory operation and adjustment has taken place of meters, flow controllers, spill valves, pressure controllers, safety valves, shut-off valves, safety devices, alarms and trips.

11.2 Personnel

During commissioning and de-commissioning operations, only personnel directly concerned shall be present within the designated area.

11.3 Oxygen Pressurisation (and Venting)

Care shall be taken to ensure that all valves are in the correct mode. Terminal valves and branch line valves shall be closed. The fitting of pressure gauges to each side of isolating valves should be considered as outlined within Section 7.1.

The oxygen shall be admitted into the pipework at a carefully controlled rate. Rapid pressurisation of the pipework shall be avoided. The pipework shall be pressurised by means of the main valve bypass (where fitted) after which the main valve shall be opened slowly. Branch lines shall be pressurised in turn.

The pipework shall be vented through a copper alloy valve and vent (where fitted). The rate of flow is to be controlled by a copper alloy valve. Where a venting system is not part of the pipework, it shall be attached to the pipework termination. All branch lines shall be vented. Vent lines shall be led into the open air and away from hazardous situations. Venting flow rates shall be controlled to ensure that pipework velocities are kept within design limits.

Where appropriate, consideration should be given to gas analysis tests to determine when all nitrogen or air has been expelled from the system.

Circumstances may exist where it is more prudent to purge directly into the process, e.g. Blast Furnace enrichment systems and Arc Furnaces.

Once oxygen has been detected, within design limits at all outlets, the outlet valves shall be closed.

Filters shall be monitored with differential pressure gauges, being isolated, elements removed, cleaned or replaced until the differential pressure lies within design limits.

Reference	Page	Issue No.	Revision No.	Date
UKS Oxygen COP	27	1	2	16/04/19

12. OPERATION OF PIPEWORK SYSTEMS

Isolation valves not fabricated from exempt materials may only be operated after opening a bypass valve or other specific procedure, to avoid the generation of a high velocity through the valve. This high velocity will occur on closing the valve against flow, or created by opening the valve against a high upstream to downstream differential pressure.

13. MAINTENANCE OPERATIONS

13.1 General

All maintenance personnel shall have clean oil-free clothing, boots, and tools, and ensure they have clean grease free hands.

Work shall be carried out in well-ventilated areas, with oxygen upper and lower limits of 23.5%, and 19.5% by volume. Oxygen monitors shall be used. Further guidance is available in BCGA GN 11: Management of Risk When Using Gases in Enclosed Work Spaces.

13.2 Preventative Non-Intrusive Maintenance

A maintenance programme should be in place. The EIGA Standard IGC Doc 13/12/E, Appendix F lists main tasks to be performed, but task frequency may be tailored to comply with company practices.

Frequency controlled preventative tasks should include: -

- testing of cathodic protection system and its isolation from non-protected parts.
- integrity of earthing/grounding system
- visual inspection of external coating system, and use of specialised surveys, such as The Pearson survey, The Current Attenuation Survey, or The Close Interval Potential Survey.

The results of these investigations shall be compared to previous and "as installed" data, to judge the integrity of the cathodic protection system. Investigations to be carried out in accordance with the designed maintenance program and typically by a specialist contractor.

- visual check on above ground flanges, supports and anchor points.
- visual check for signs of unauthorised interference, land subsidence, accidental damage, and that pipework marking devices are in place.

If leakage is suspected but cannot be located through visual or audible evidence, the pipework shall be isolated in sections, and pressure tested to identify the source of the leak, or prove the pipework is sound.

13.3 Intrusive Maintenance

A positive shut-off is required prior to major work being carried out

Before opening pipework it shall be de-commissioned. Flanges and adjacent pipework shall be cleaned externally before being disconnected so as to prevent foreign matter entering the pipe. Special care must be taken to ensure the surrounding area must be as clean as practicably possible during intrusive maintenance. During maintenance work the same attention to cleanliness shall be observed as for a new installation. In particular no foreign matter especially, oil and grease shall be allowed to enter the pipe and projections in the pipe avoided.

Oxygen shall be vented to an unoccupied area, free from other hazards, such as ignition sources, combustion engines and overhead power lines. The affected pipework shall be purged using dry oil-free air or nitrogen.

On completion of the work, the pipework shall be cleaned by pigging wherever possible (refer to section 9.3.1), followed by nitrogen or air blow-out as Section 9.3.4 and re-pressure tested in accordance with Section 9.2 in as far as they can be applied and re-commissioned in accordance with Section 11.

Very minor work which does not require any fabrication, e.g. changing a flanged valve or similar piece of equipment, may be undertaken at the discretion of the appointed competent person, with every care taken to ensure maximum system cleanliness. (Note the externals of the pipework in the vicinity of the repair must be thoroughly cleaned before the pipework is opened.)

Reference	Page	Issue No.	Revision No.	Date
UKS Oxygen COP	28	1	2	16/04/19

Replacement consumable items, e.g. outlet valves should be clearly identified as suitable for oxygen purpose and should be kept in a sealed bag with adequate labelling.

14. INFORMATION TO 3rd PARTIES, WORKS ADJACENT TO PIPEWORK & DOCUMENT UPDATES

Statistics show that two thirds of accidents occurring on underground Pipework are caused by external events. Therefore national regulations must be followed in terms of notification to third parties, with up to date records maintained of pipe system locations, and status within the lifecycle.

Third party interference shall be controlled by:-

- maintenance of marker posts on the pipework route,
- distribution of “as-laid” drawings to relevant third parties,

Oxygen pipework and pipework systems shall be included in the site emergency plan or equivalent.

15. LIFECYCLE DOCUMENTATION

All documentation should be compiled and retained by the owner of the pipework/pipework system. See Section 7.7 of The EIGA Standard IGC Doc 13/12/E for guidance.

Reference	Page	Issue No.	Revision No.	Date
UKS Oxygen COP	29	1	2	16/04/19

APPENDIX A

Materials

A1 Materials that will normally be safe for pipe work:

Stainless Steel

Mild Steel

Cast Steel

Zinc

Polytetrafluorethylene (PTFE)

A2 Materials safe under all conditions (will not normally ignite):

Copper

Brass, Bronze and Monel

Silver

Nickel and its alloys

A3 In the case of other materials (including jointing materials) advice shall be sought from a competent authority.

Reference	Page	Issue No.	Revision No.	Date
UKS Oxygen COP	30	1	2	16/04/19

APPENDIX B

Degreasing Agents

The following are approved for use in oxygen systems, but attention is drawn to the fact that other restrictions may apply.

	LTEL	STEL
Trichloroethylene (MEL) for pipe cleaning only	100 ppm	150 ppm
Methylene Chloride (Dichloromethane) (MEL) particularly suitable for long and complex pipe runs since its low boiling point allows easier removal than other fluids	100 ppm	300 ppm
1.1.2 trichlorotrifluoroethane (OES) because of expense, should only be used for information	1000 ppm	1250 ppm

Note

1. **1,1,1-Trichloroethane** must not be used (Ref Montreal Protocol 1987)
2. **Carbon Tetrachloride** must not be used (Ref Montreal Protocol 1987)
3. LTEL is the Long Term Exposure Limit (8 hour TWA reference period)
4. STEL is the Short Term Exposure Limit (15 minute TWA reference period)
5. As part of the COSHH assessment a "Safety Data Sheet" should be provided by the supplier.
6. Either prior or after selection of a potentially suitable degreasing agent by the Engineer, it is essential that a suitable and sufficient COSHH Assessment is undertaken by a competent assessor to confirm that use of the degreasing agent is acceptable.

Reference	Page	Issue No.	Revision No.	Date
UKS Oxygen COP	31	1	2	16/04/19

APPENDIX C

DESIGN AND CONSTRUCTION OF STATIONS

A control station controls and meters gas in conjunction with a supply pipework.

The station shall be designed, meeting the criteria laid down in this Code of Practice with regard to materials, oxygen velocity principles, following a quality plan as described for pipework fabrication and installation, earthing and grounding etc.

Stations shall be designed, fabricated, inspected and tested in accordance with international standard, such as ASME B31.1

Stations shall be surrounded by a protective barrier to shield “outside” persons and property, and to protect the station from external energy impacts. Barrier design criteria is further described in The EIGA document 13/12E, Section 8.5.2 “Design Criteria”.

Station location is important to limit risks of external energy influences affecting the station, and to limit the risk imposed by the station’s energy on external persons and property. The EIGA Standard, Section 8.6 “Location” offers further advise, and Appendix E of The EIGA document 13/12E, provides a summary of acceptable distances that Stations should be positioned from other site assets.

For Station Commissioning requirements, see Section 10 of this document

The stations control strategy shall be devised to control the pipework supply safely within the design envelope. Variables to control within the strategy can include:-

- Pressure: to control pressure to within design and operational limits, and protect against over pressure, although the pipework design will be rated for above maximum operating pressure.
- Temperature to ensure cryogenic liquids are prevented from entering the system
- Flow: to match customer demand from the system
- Product purity: to ensure product that fails to meet the specification does not enter the system.

Reference	Page	Issue No.	Revision No.	Date
UKS Oxygen COP	32	1	2	16/04/19

APPENDIX D Self-Sealing Safety Adapter

Materials as specified within
Appendix A

BULLNOSE TO BE A PUSH FIT INTO VALVE BODY

ARRANGEMENT OF ADAPTOR WHEN ASSEMBLED

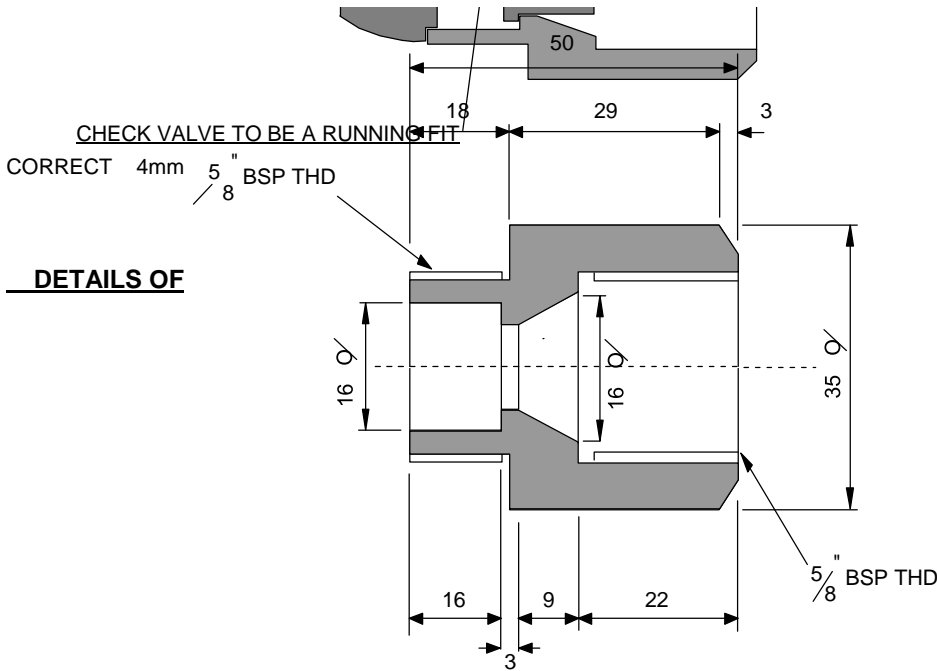

DETAILS OF VALVE BODY

19 mm RADIUS CRITICAL FOR
DIAMETER HOLE
OPERATION OF ADAPTOR

DETAILS OF BULLNOSE CHECK VALVE

DETAILS OF

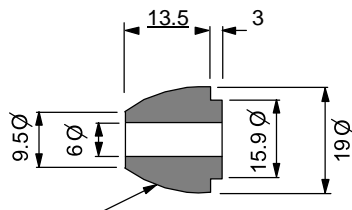

DETAILS OF BULLNOSE

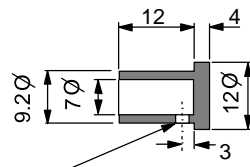

DETAILS OF CHECK VALVE

Reference	Page	Issue No.	Revision No.	Date
UKS Oxygen COP	33	1	2	16/04/19

APPENDIX E

OXYGEN LINE VALVE AND SELF-SEALING ADAPTER

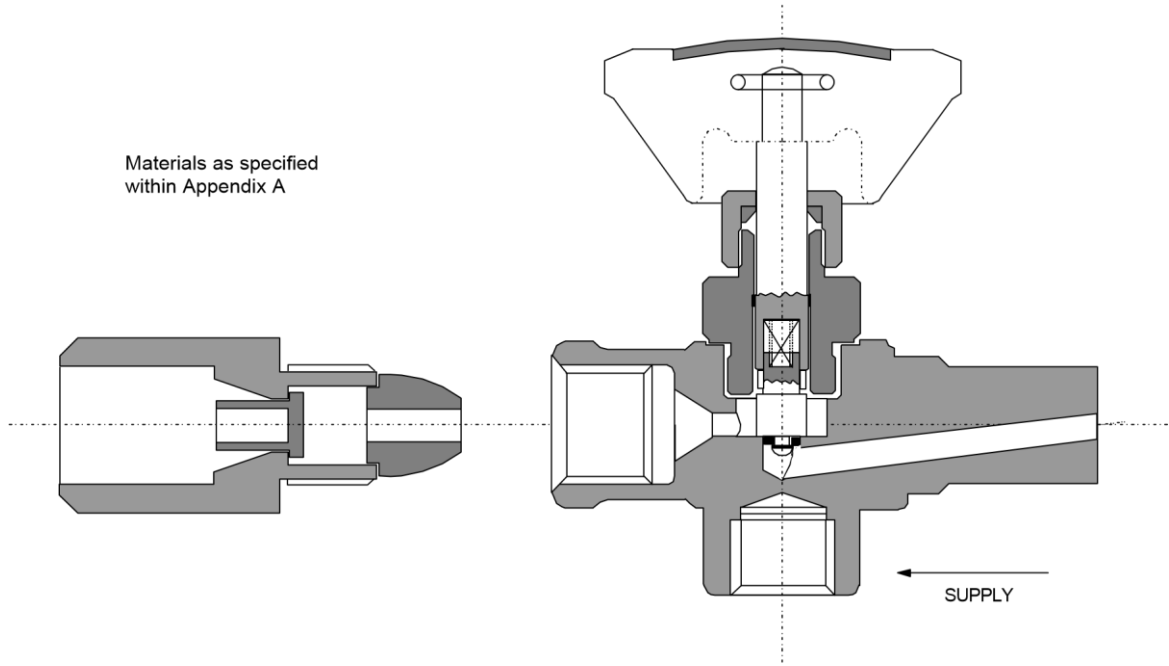

Reference	Page	Issue No.	Revision No.	Date
UKS Oxygen COP	34	1	2	16/04/19

APPENDIX F

Oxygen Outlet Identification Sign



Reference	Page	Issue No.	Revision No.	Date
UKS Oxygen COP	35	1	2	16/04/19